

Brighter and Cooler

Lower Thermal Resistance & Junction Temperature

Apollo 1200 Chip on Board is a high-performance LED module based on Flip Chip Opto's patented **3-Pad LED Flip Chip** and **Pillar MCPCB** technologies. Both junction temperature and thermal decay are minimized due to its extremely low thermal resistance, and therefore illumination designers are able to maximize the "lumen per dollar" value through solutions such as brightness booster, smaller heatsink and optics.

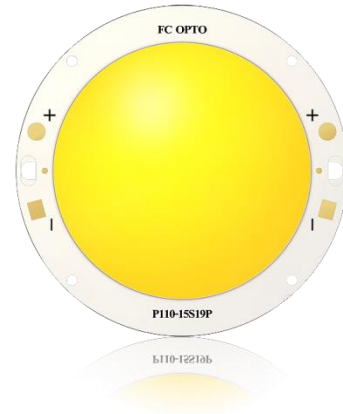
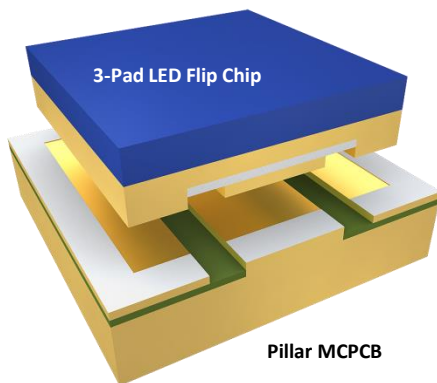

Features:

- Patented COB Technologies
- 1216.8W Maximum Power
- 0.006°C/W Thermal Resistance
- Available in 4000K, 5000K, 5700K CCT
- Available in 70-, 80-, 90- CRI Options
- 90mm Light Emitting Surface
- 45x45mil Flip Chips (Patented)
- Copper Based Pillar MCPCB (Patented)
- No Wire Bonding
- Low Temperature Bonding
- RoHS Compliant

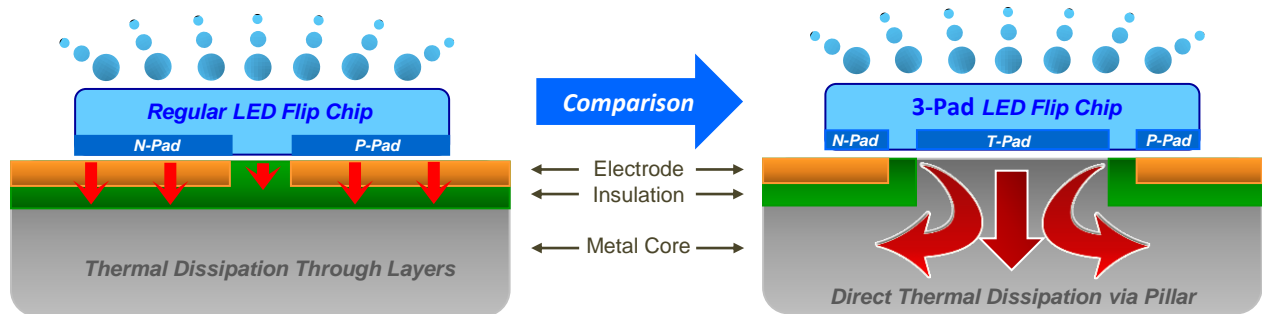

Absolute Maximum Ratings (Ta=25°C):

Parameter	Symbol	Max. Rating	Conditions
Power Dissipation	P_d	1216.8W	$T_j \leq 140^\circ\text{C}$
DC Forward Current	I_f	24,000mA	$T_j \leq 140^\circ\text{C}$
Junction Temperature	T_j	140°C	
Reverse Voltage	V_r	-5V	$T_{\text{ambient}} = 25^\circ\text{C}$
Reverse Current	I_r	$\leq 1\mu\text{A}$	$V_r = -5\text{V}$
Operating Case Temperature	T_c	-40°C to 105°C	
Storage Temperature	T_{ST}	-40°C to 120°C	
Soldering Conditions		280°C < 3.5 secs	

Electro-Optical Characteristics (Ta=25°C):

Viewing Angle $2\theta_{1/2} = 140^\circ$

Nominal CCT	Apollo Part Number	CRI (min)	Luminous Flux (lm) @ $I_f = 24\text{A}$	V_f (V) @ $I_f = 24\text{A}$	LES (mm)
5000K	Apollo 1200-5070	70	121,680	50.7	90
5000K	Apollo 1200-5080	80	118,030	50.7	
4000K	Apollo 1200-4070	70	118,100	50.7	
3000K	Apollo1200-3080	80	107,080	50.7	

Thermal Characteristics:

Parameter	Symbol	°C/W	Definition
Thermal Resistance	$R_{th(j-b)}$	0.006	Between LED Junction and COB Bottom Surface

- Junction Temperature $T_j = T_b + \text{Power(W)} \times R_{th(j-b)}$, where T_b is the temperature at COB bottom surface.
- T_{CM} Measurement point shown in the Mechanical Dimension is an extension of the COB metal core, and the temperature at T_{CM} is applied as a reference to T_b .



Bins on the ANSI C78 :

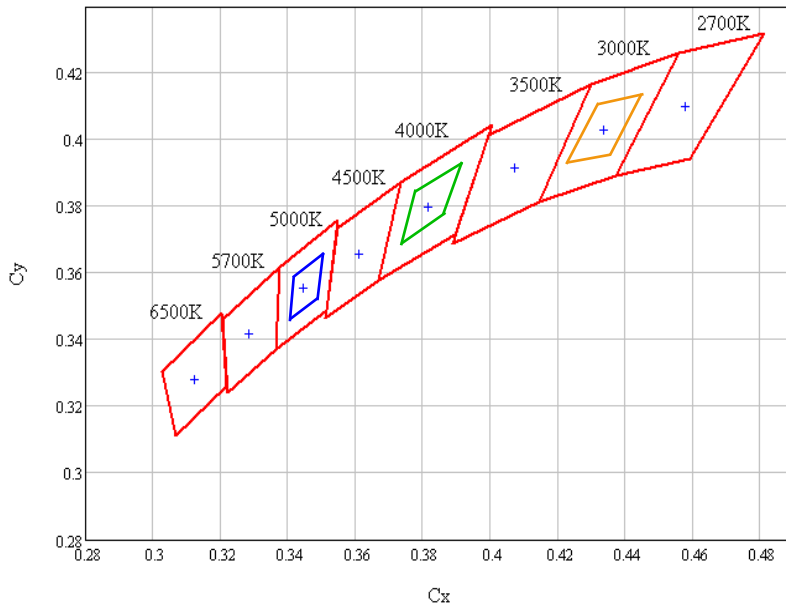

Nominal CCT	x	y
3000K	0.4242	0.3919
	0.4322	0.4096
	0.4449	0.4141
	0.4359	0.3960
4000K	0.3744	0.3685
	0.3782	0.3837
	0.3912	0.3917
	0.3863	0.3758
5000K	0.3407	0.3459
	0.3415	0.3586
	0.3499	0.3654
	0.3484	0.3521

Spectrum (Ta=25°C):

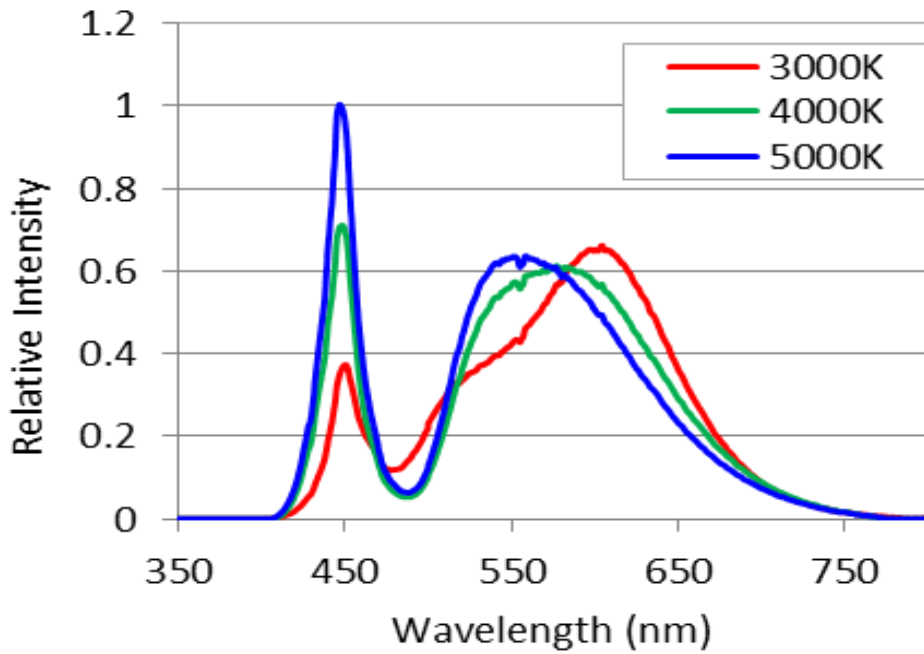

Characteristic Graphs (Ta=25°C):

(i) Typical Forward Current (I_F) vs. Forward Voltage (V_F)

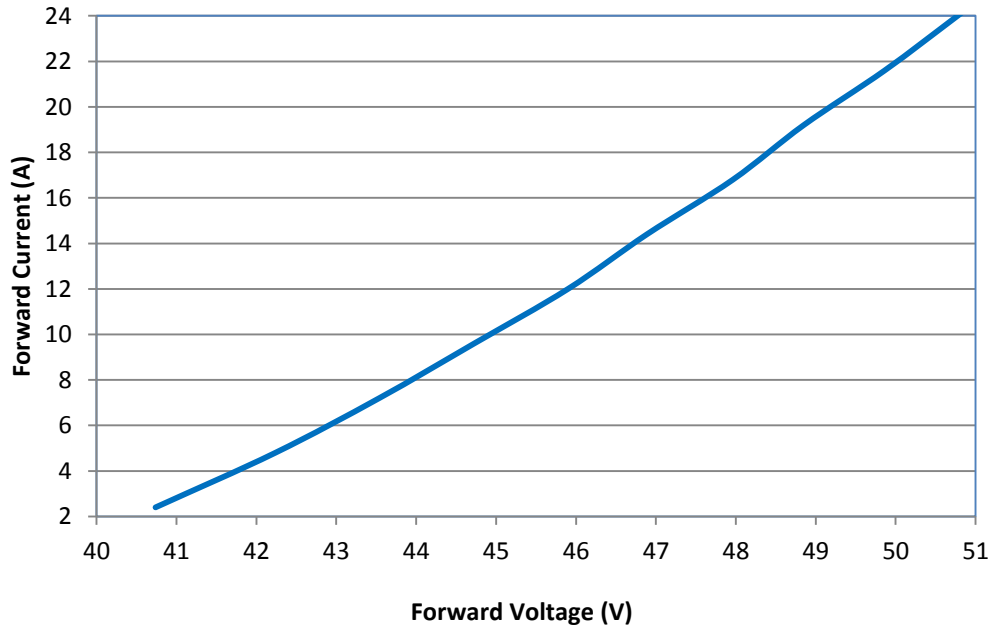

(ii) Typical Normalized Luminous Flux vs. Forward Current (I_F)

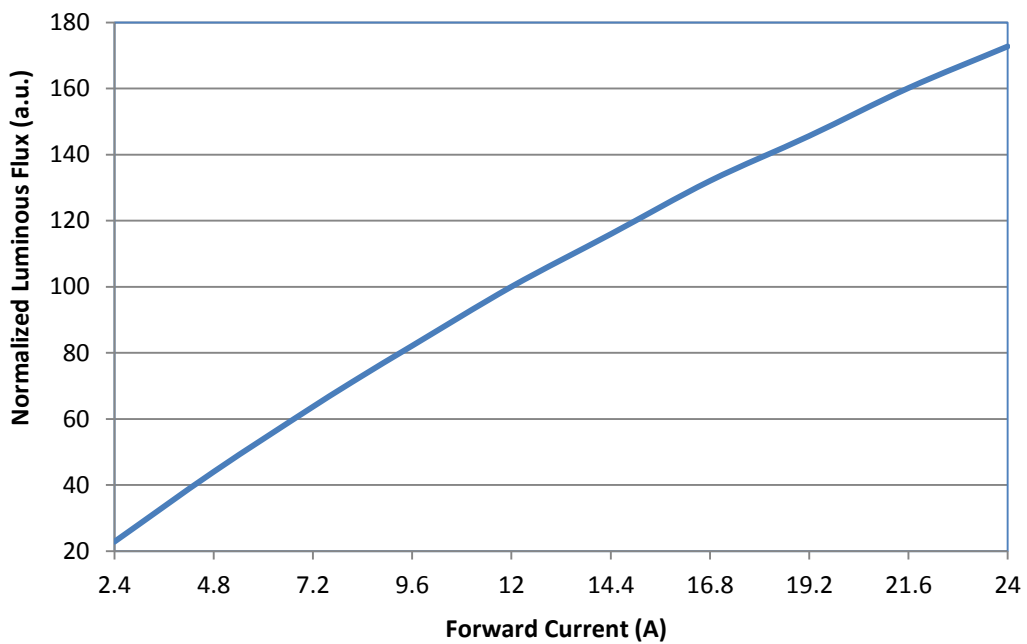

(iii) Typical Spatial Radiation Pattern

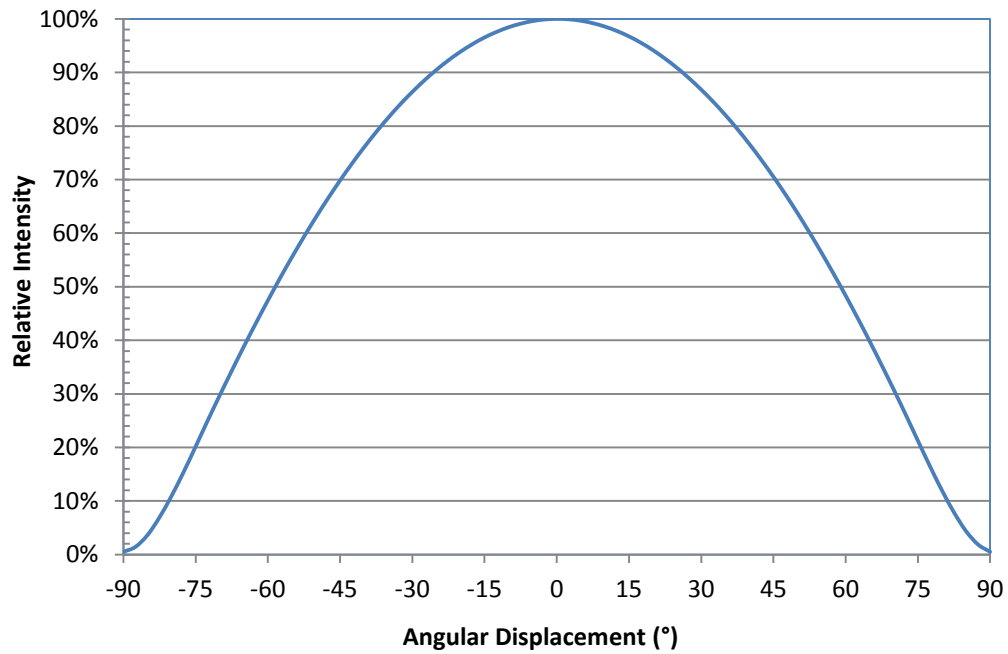

(iv) Typical Polar Radiation Pattern

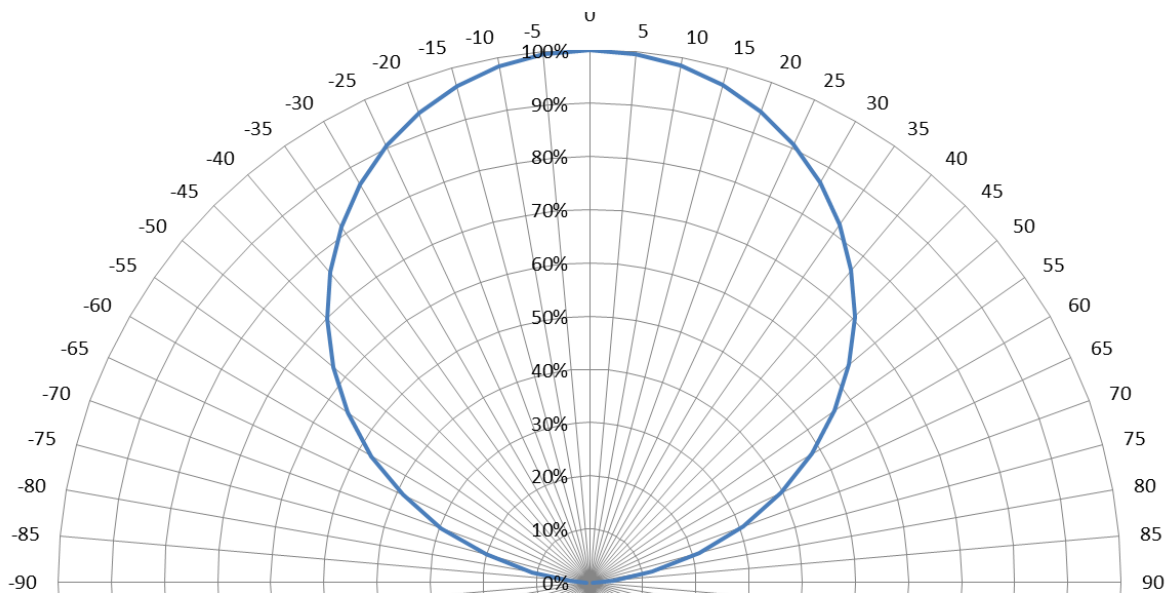

(v) Allowable Forward Current (I_F) vs. Case Measurement Temperature (T_{CM})

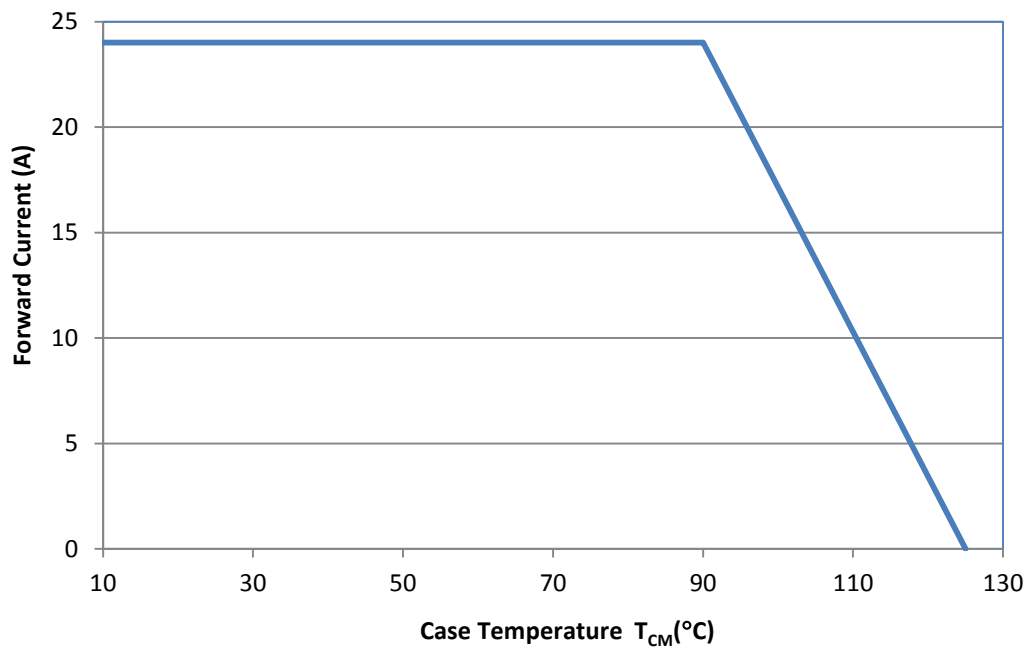

Mechanical Dimensions:

- Solder pads are labeled “+” and “-” to denote positive and negative, respectively.
- Drawing dimensions are in millimeters, and are not to scale.
- Tolerance: ±0.2mm
- The optical center of the LED Array is defined by the mechanical center of the array.

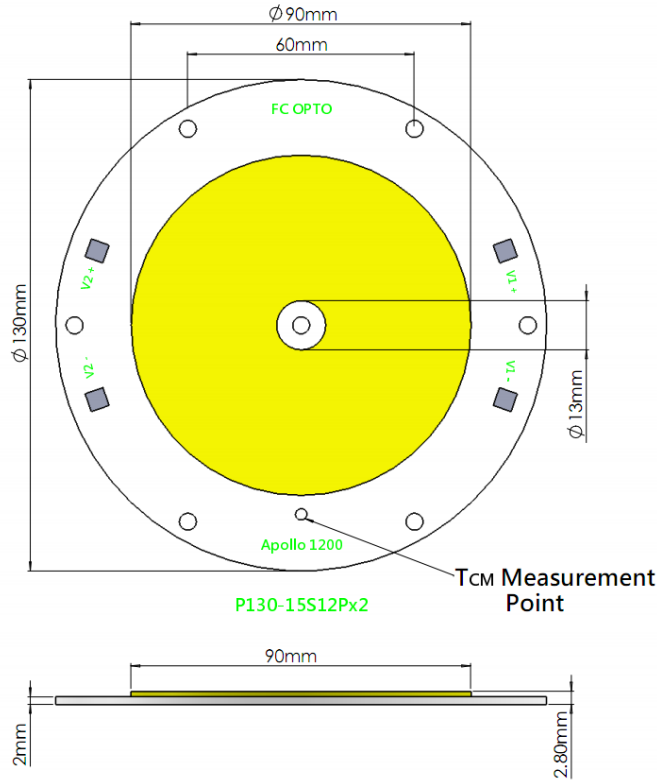

Circuit Diagram - Two Identical but Separated Circuits

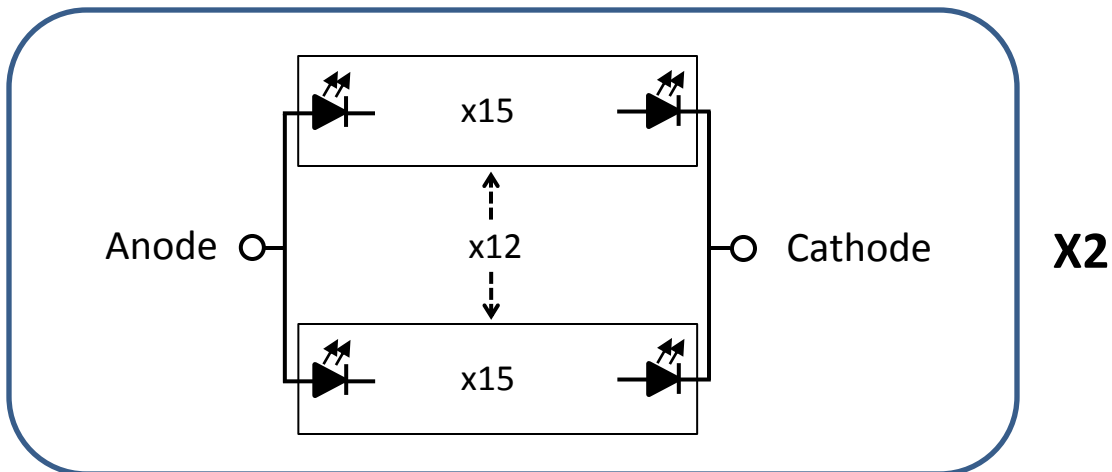

Reliability Tests:

Item	Reference	Condition	Duration
Operating Endurance Test	Internal Reference	Ta=25°C, I _F =18A	1,000 hrs
Accelerated Aging Testing	Internal Reference	85°C and 85 % Humidity	5,000 hrs
High Temperature Storage	Internal Reference	100°C	1,000 hrs
Low Temperature Storage	Internal Reference	-40°C	1,000 hrs

**3-Pad Technology Burn-In Test @ Case Temperature T_{CM}=105°C
Reference: Apollo 20**

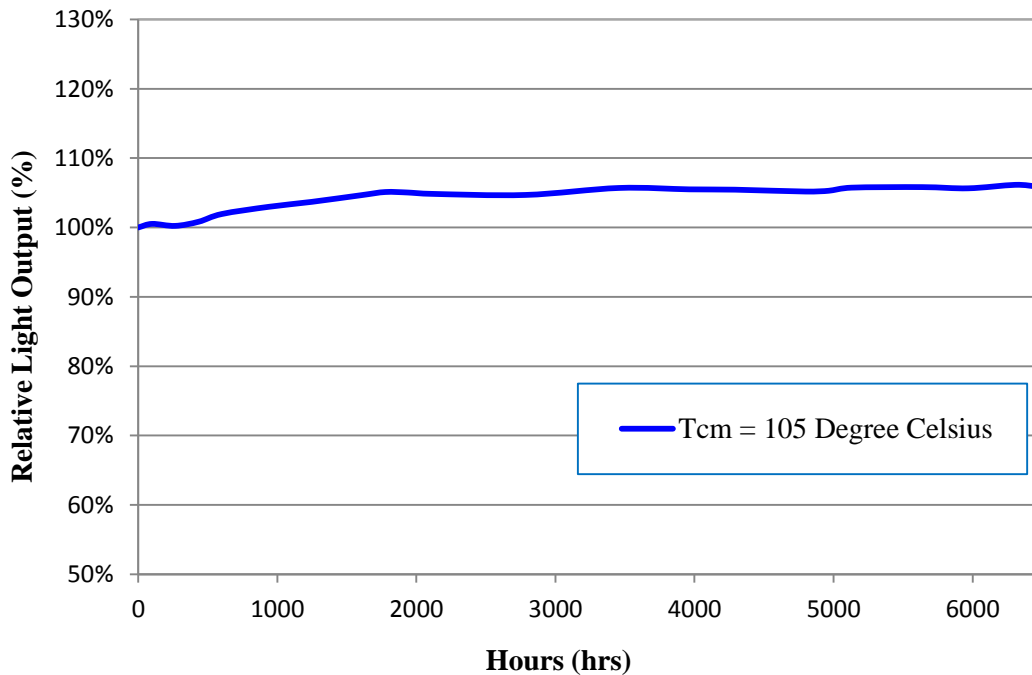

After 6000 hours burn-in under T_{CM}=105°C condition, Flip Chip Opto COB Apollo 1820 remains robust without performance degradation.

Cautions:

1. Circuit Protection is recommended during the assembly and operation.
 - i. MOV, TVS, current fuse, thermal fuse, capacitor, resistor are options to avoid unexpected circuit faults.

2. Storage Conditions
 - i. Moisture Controlled environment is recommended to avoid COB damages during storage. Moisture may cause circuit damages and result in brightness reduction or failure in circuit contacts.
 - ii. COB in moisture-proof sealed bags should be stored in ambient conditions of temperature less than 30°C and humidity less than 90%RH.
 - iii. COB in open air should be kept in ambient conditions of temperature less than 30°C and humidity less than 60%RH.
 - iv. COB should be restored in moisture-proof bag with moisture absorbent together.

3. Handling Light Emitting Surface (LES)
 - i. LES is a silicone lens and should not have direct contact with sharp tools and human fingers.

4. Recommendation on Assembly with Heat Sink
 - i. Apply thermal grease over the heatsink contact surface to seal the voids and roughness pre-existing on the contact surface.
 - ii. Attach COB onto heatsink contact surface with thermal grease in between. Thermal grease thickness is suggested less than 25um (1 mil)
 - iii. Apply sufficient pressure to secure the COB, and ensure (a) full contact between COB and heatsink, (b) no voids within thermal grease, (c) minimal thermal grease thickness.

5. Flip Chip Opto is not responsible to the damages caused by the operation under the parameters exceeding the values described in the specification.